

VL149

LTE Vehicle Terminal

User Manual V1.0

No part of this document may be reproduced, retranslated, or copied in any form or by any means or for profit (electronic, photocopying, taping, etc.) without written permission of the Company.

The product specifications and information in this document are for reference only and no prior notice will be given if any change is made. Unless otherwise stated, the content of this document is not a guarantee in any form.

Disclaimer
©All Rights Reserved

Overview

Description

VL149 is a portable compact 4G Cat.1 GPS tracker for tracking and monitoring automobiles, motorcycles, electric two-wheelers, and other types of transportation whose voltages range from 9V to 90V. It has a built-in GPS antenna with good RX capabilities for precise position fixes. It can offer optional TTL interfaces. The 4G capability enables it to be widely used in different countries and regions.

The black appearance makes the VL149 easy to hide on a vehicle. It can fix positions in real-time, generate tracks of traveled routes, send out alerts for exceptions, help immobilize vehicles by cutting off fuel and power supply, and other functions, making it a suitable choice for businesses trying to lower their management risks, protect the vehicles from theft.

Product Schematic Diagrams

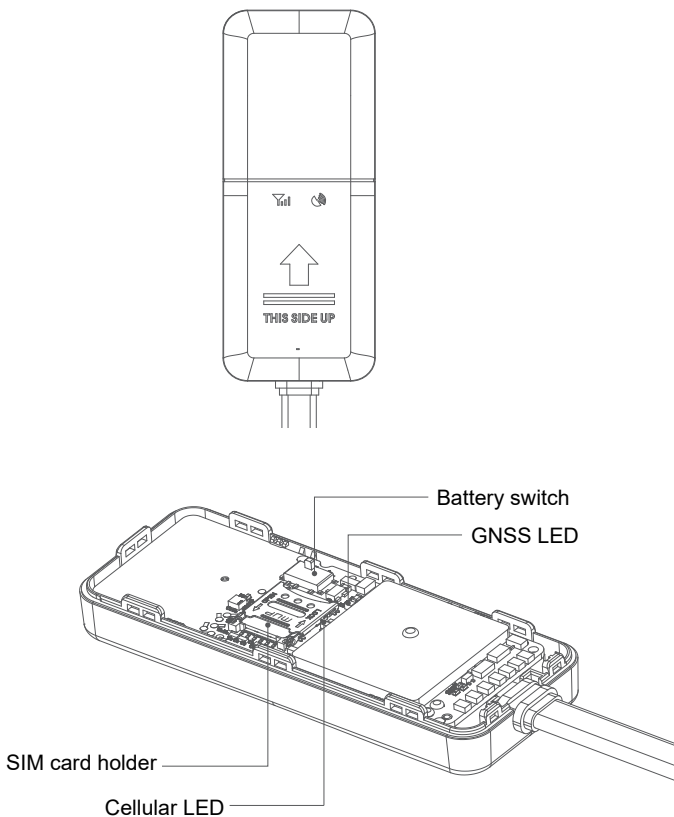

Accessories

VL149	1	PCS	–
Power cable	1	PCS	–
Relay	1	PCS	Optional

Definitions of Interfaces

4-Pin Connector (Standard):

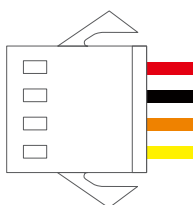

V+	Red	To the positive end (9–90V)
V-	Black	To the negative end
ACC	Orange	For ACC detection
RELAY	Yellow	For cutting fuel/power supply

4-Pin Connector (Optional):

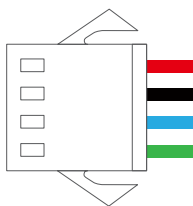

V+	Red	To the positive end (9–90V)
V-	Black	To the negative end
Tx	Blue	To peripherals such as SOS button
Rx	Green	To peripherals such as SOS button

2-Pin Connector (Optional):

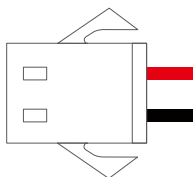

V+	Red	To the positive end (9–90V)
V-	Black	To the negative end

Connotations of LEDs

GNSS LED (Blue)

Fast blink [0.3s-0.3s (on-off)]	The device is searching for satellite signals.
Solid on	Position fixed
Off	The GNSS module is in sleep or not operating.

Cellular LED (Green)

Fast blink [0.3s-0.3s (on-off)]	Network initialization.
Slow blink [1s-3s (on-off)]	The cellular module works normally.
0.1s-3s (On-Off)	The device goes online.
Solid on	The device is engaged in a call.
Off	No GSM signal/No SIM card

External Power Status

Blue and green LEDs solid on for 3s	Plug or unplug the external power source
-------------------------------------	--

Note

The two LEDs will go off after the device operates correctly for a while. You can unplug and plug the external power source to activate them or you can deliver a command to keep them always on.

Introduction

Specifications

Network Communication	
System	4G
Bands	FDD: B1/ B3/ B5/ B8
	TDD: B34/B38/B39/B40/B41
Max. Output Power	LTE-TDD: Class3 (23dBm+1/-3dB)
	LTE-FDD:Class3 (23dBm±2dB)
RX Sensitivity	TD-LTE: ≤ -96dBm (10M)
	LTE-FDD: ≤-96dBm (10M)
GNSS Parameters	
Frequency	BDS B1, 1561.098MHz;
	GPS L1, 1575.42MHz
No. of Channels	64
Antenna	25mm x 25mm x 2mm
Positioning Accuracy	2.5m CEP
Tracking Sensitivity	-165dBm
Acquisition Sensitivity	-148dBm
TTFF	Avg. hot start: ≤2s (open sky)
	Avg. cold start: ≤28s (open sky)
Overall Specification	
Antenna	Built-in GPS ceramic antenna
LEDs	GNSS (blue), Cellular (green)
Battery	60mAh/3.7V industrial-grade Li-polymer battery
Operating Voltage	9-90VDC
Standby Current	≤5mA (battery-powered)
Device Color	Black
Dimensions (LxWxH)	80mm x 31mm x 13.6mm
Operating Temperature	-20 °C to +70 °C
Interface	4-Wire edition (standard): P+, P-, ACC, and relay for power connection, ACC detection, and power/fuel cutoff
	2-Wire edition (optional): P+ and P-
	4-Wire edition (serial): P+, P-, TX and RX for power connection and communicating with external devices. The TX and RX wires can also be changed to be able to connect with an SOS button.

Features

Real-time Tracking

The positioning accuracy could reach under 10m under open sky.

Power-cut Alert

An alert will be triggered if the power supply to the device is disconnected or its power cable has been cut.

Tamper Alert

An alert will be triggered if the device is removed.

Driving Behaviors

Harsh Acceleration

The device will report a harsh acceleration event to the platform when it detects the vehicle's speed increases abruptly due to a hard stepping on the accelerator.

Harsh Braking

The device will report a hard braking event to the platform if it detects the vehicle's speed decreases abruptly.

Sharp Cornering

The device will report a harsh turn event to the platform if it detects the vehicle is cornering sharply during moving.

Collision

The device will report a collision event to the platform if it detects the vehicle in motion collides with another object or vehicle.

Low External Power Alert

If the device detects the voltage of the external power is under the preset threshold, it will send out an alert message.

Low Internal Battery Alert

If the device detects that the voltage of its internal battery is lower than the preset threshold, it will send out an alert message.

Geofence Alert

Provided that you have set a geofence and the alert conditions on the designated platform, you will be alerted if the device detects the vehicle enters or leaves the geofence and the alert conditions are met.

Speed Alert

Provided that you have set the speed limit for the vehicle on the platform or via SMS, you will be alerted if the device detects the vehicle moves at a speed greater than the speed limit for a set duration.

Vibrating Alert

If the device detects any vibration when the vehicle stops and has its ignition off, it will send out an alert.

Installation

Installing the Device

Device check

Check visually whether the device is in good condition and whether the relevant accessories are complete.

SIM Card Attachment

- Prepare a proper SIM card.

For size details, refer to the following figure.

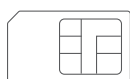

Standard ❌



Micro ❌



Nano ✔️

- Insert the SIM card (power off the device before inserting or removing the SIM card) as the following figure shows:

Remove the top cover with your fingers at the buckle of the shell

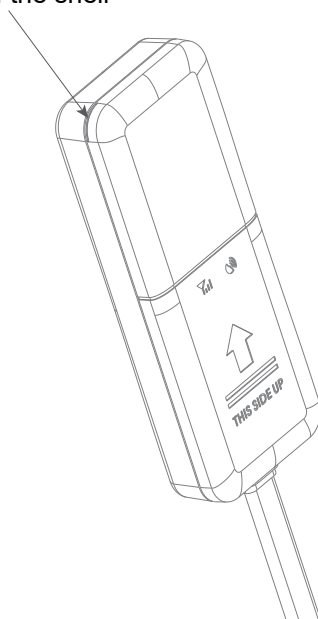

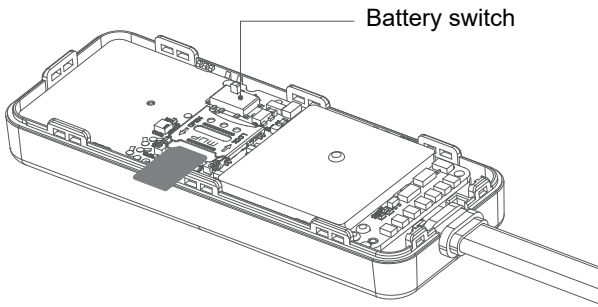

After the SIM card is inserted in place, slide the battery switch to ON.

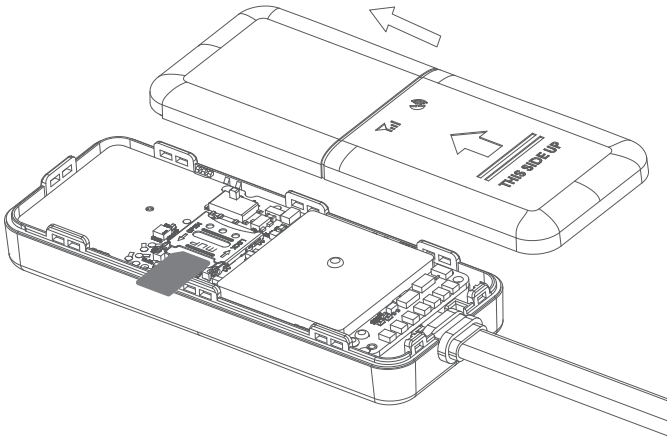

Attach the shell back

Note

The SIM card should be inserted correctly. Make sure the SIM has data services activated and is not in arrears. Disconnect the external power and slide the battery switch to OFF before inserting or removing the SIM card. After the SIM card is placed in the slot, slide the battery switch to ON and lock the SIM.

Wiring Diagram for Motorcycles and Electric Two-Wheelers

- Use a multimeter to determine the positive and negative wires of the battery.
- Use the multimeter to determine the ACC wire. Provided the black and red probes of the multimeter are connected with two wires separately, if the multimeter reads 0V when the key points to OFF and reads the same as the supply voltage of the vehicle when the key points to ON, then the wire connected by the red probe of the multimeter is the ACC wire.
- Connect the red wire (positive) of the device power cable with the positive pole of the motorcycle battery.
- Mate the connectors as the following figure shows.

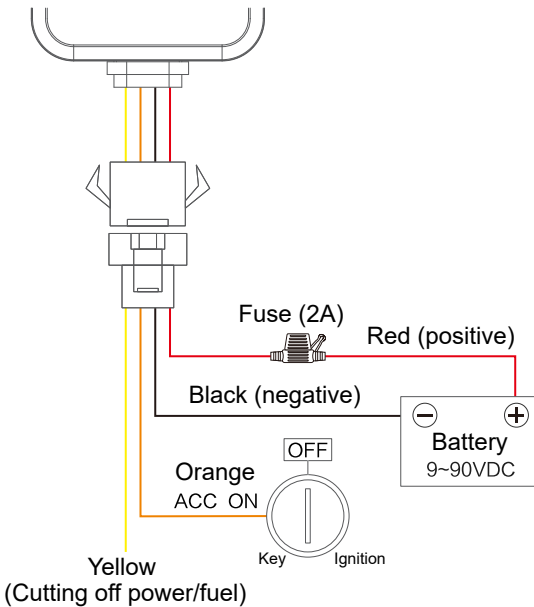

Possible Install Positions for Electric Two-Wheelers

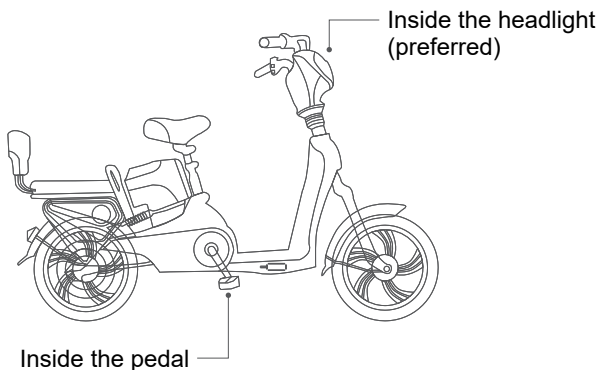

Possible Install Positions for Electric Two-Wheelers

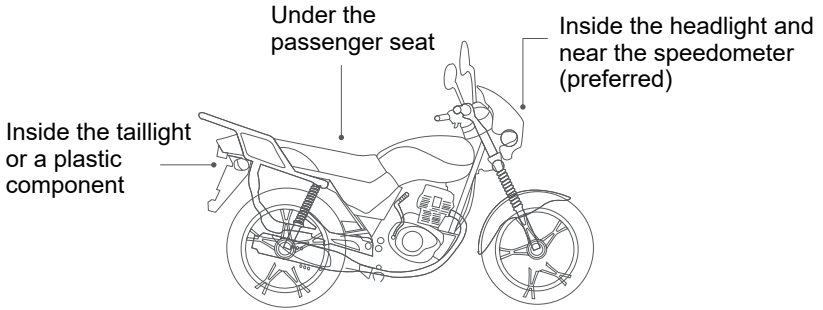

Note: If the device is installed under the rider, the strength of satellite signals reaching the device will be seriously affected.

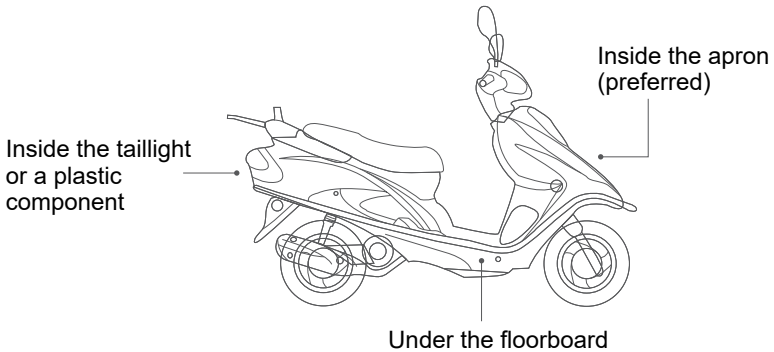

Wiring Diagram for Automobiles

- Use a multimeter to determine the positive and negative wires of the battery.
- Use the multimeter to determine the ACC wire. Provided the black and red probes of the multimeter are connected with two wires separately, if the multimeter reads 0V when the key points to OFF and reads the same as the supply voltage of the vehicle when the key points to ON, then the wire connected by the red probe of the multimeter is the ACC wire.
- Connect the red wire of the device power cable to the positive pole of the vehicle battery.
- Mate the connectors as the following figure shows.

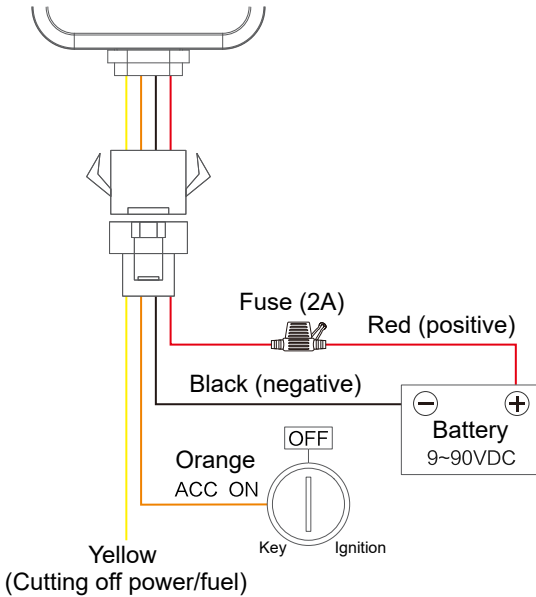

Note

- Choose accessories specified by the manufacture.
- The standard supply range is 9–90V, please use the original power cable and ensure that the positive and negative ends are correctly wired.
- Description on device installation

To ensure that the device is installed and debugged correctly, professional agencies and personnel designated by your dealer are recommended. See the following figure for install positions:

Possible Install Positions for Automobiles

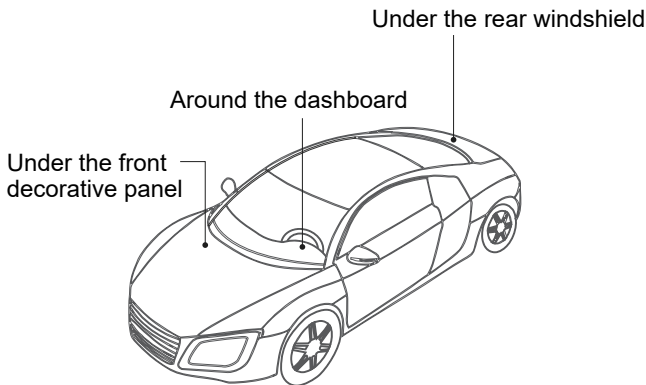

Note

- Make sure the front side of the device is facing to the sky;
- Avoid positions where a metal insulation layer or heating layer may exist; as such a layer may affect the strength of satellite signals reaching the device.

Platform Operations

Logging In to Service Platform

You can configure and control the device via the designated location service platform.

You can download the mobile app via the URL provided by your dealer.



iOS



Android

Appendix

Battery Safety

- Please use batteries that are specified by the manufacturer of the device. The use of any non-original accessories will void the warranty services. The manufacturer will disclaim any repair liabilities for damages caused by the use of any non-original accessories.
- Avoid metal objects as they may cause short circuits on battery contacts.
- Do not bend or forcibly open the battery.
- Do not soak the battery in water or expose it to fire.
- Charge the battery at room temperature. If the temperature is lower than 0 C or higher than 45 C during charging, the battery may fail to be charged.
- It is forbidden to use batteries that are deformed, discolored, spilled, or package-damaged.
- It is forbidden to disassemble or modify the battery.

Troubleshooting

When an issue arises, you can troubleshoot it by the following solution. If the issue persists, please do not hesitate to contact your dealer or service provider.

Issue	Description	Solution
Poor satellite signal	The device may be used in a place where the satellite signals cannot be perfectly penetrated, such as at lower stories of a high-rise building or in a basement.	Try it in a place where satellite signals can be well received.
	The device is facing downward or is blocked by metal objects.	Adjust the device so its front side facing upward or install it in another position.
Power-on failure	The battery is low.	Connect the device to an external power source to charge the battery.
	fuse burn-out	Contact your dealer for a replacement.
Failed to access the network	The SIM card is attached incorrectly.	Re-attach it.
	The metal side of the SIM card is stained.	Wipe it with a clean cloth.
	The SIM card is damaged or invalid.	Replace it.
	The device is operated out of the network coverage.	Try it in a service area.
	The signal is poor.	Try it in an area with strong signals.
Failed to charge	The contact is poor.	Check if the power cable is connected securely.
Failed to query a location	The SIM card is not activated with data services.	Please contact your network operator to activate data services.
	The SIM is in arrears.	Recharge the SIM.
	The device does not respond to a command.	Check the device and make sure that the device can access the network and the SIM card has text services activated.

Warranty Instructions and Service

Special Note

No prior notice will be given if the product is upgraded due to technological reasons.

The appearance or color of the product is subject to the actual.

The warranty card applies to the services of repair, replacement and refund of the product with the following IMEI.

Please keep this warranty card and the original purchase receipt together in a safe place, as these will be needed at time of services.

Warranty Terms

For damages not caused by human factors, this warranty lasts for two years (including one-year replacement service) from the date of original purchase.

You can choose to pay for the repair services in any of the following cases:

- The warranty card expires;
- No warranty card or valid proof of purchase;
- The product or its accessories are not in the warranty period;
- Damage caused by unauthorized repairs, crash, liquid spillage, incident, accident, modifications, or incorrect voltage input; or the label, IMEI, or counterfeit mark of the product is broken or scribbled;
- Damages caused by installation or use not in accordance with this Manual;
- Damage caused by force majeure such as fire, flood, or lightning;
- The device model is inconsistent with that on the warranty card or the warranty card has been altered;
- Other damages caused by force majeure.

Note

As of January 1, 2016, the warranty lasts for 2 (two) years for repair from the date of purchase, including one year for replacement.

The specific terms are:

- A full replacement, including accessories, if the product is found defective during unpacking check (product not used);
- If a defect occurs within one year after installation, then:
Replace only the mainboard if the housing is intact and doesn't affect normal use; or
Replace the housing and the mainboard if the housing is defective and affects normal use (Please note that man-made damages will void the replacement service for the housing);
- Free repair services will be given to the product if a defect is found during the second year under proper use.